

## All optical wavelength conversion for stimulated Raman scattering based on photonic crystal fiber

Gong Jiamin, Meng Linghe, Yang Meng, Guo Tao, Guo Cui

(School of Electronics Engineering, Xi'an University of Posts and Telecommunications, Xi'an 710121, China)

**Abstract:** The Raman wavelength conversion was studied and numerically demonstrated which was based on the theory of forward transient stimulated Raman scattering in photonic crystal fiber, which has high nonlinear coefficient. Design scheme and implemented method of the theoretical model of all optical wavelength conversion are presented. The simulation was calculated by OptiSystem with 4 continuous probing signals. The simulation results show that the all-optical wavelength converter can convert 4 probing light in the same time, and the output signal light patterns and input pumping signal light pattern have the same waveform. Furthermore, the simulated eye diagram has a clear line and good opening degree. The feasibility is verified by the scheme.

**Key words:** photonic crystal fiber; stimulated Raman scattering; all optical wavelength conversion; high nonlinear coefficient

**CLC number:** TN929.11    **Document code:** A    **DOI:** 10.3788/IRLA201645.1206011

## 基于光子晶体光纤的受激拉曼散射全光波长转换研究

巩稼民, 孟令贺, 杨 萌, 郭 涛, 郭 翠

(西安邮电大学 电子工程学院, 陕西 西安 710121)

**摘 要:** 基于光纤中前向瞬态受激拉曼散射效应分析理论, 利用光子晶体的高非线性特性, 对光子晶体光纤拉曼波长转换进行了数值分析, 并建立了全光波长转换设计方案的理论模型, 给出了设计原理框图及实现方法。用 OptiSystem 对四路探测光进行波长转换仿真, 仿真结果表明: 所设计的全光波长转换器同时对四路探测光实现波长转换, 转换输出的信号光码型和输入泵浦信号光码型一致, 并且所得到的眼图线迹清晰, “眼睛”张开度良好。论证了该设计方案可行。

**关键词:** 光子晶体光纤; 受激拉曼散射效应; 全光波长转换; 高非线性

收稿日期: 2016-04-05; 修订日期: 2016-05-03

基金项目: 西安邮电大学研究生创新基金项目(CXL2015-04, CXL2015-21)

作者简介: 巩稼民(1962-), 男, 教授, 硕士生导师, 博士, 主要从事光通信技术、非线性光学方面的研究工作。Email: gjm@xupt.edu.cn

通讯作者: 孟令贺(1990-), 男, 硕士, 主要从事光信息传输技术方面的研究工作。Email: menglinghe1105@163.com

## 0 Introduction

All optical wavelength conversion may find use in future optical networks as it enhances transparency, interoperability, and capacity of dense wavelength division multiplexed (DWDM) networks<sup>[1-2]</sup>. Stimulated Raman scattering (SRS) in nonlinear optical fibers is a promising approach to flexible wavelength conversion as it has the characteristics of a high threshold.

Nonlinear photonic crystal fiber (PCF) provides a good medium for DWDM wavelength conversion due to its high nonlinear coefficient. Its concept was first proposed by Russell ST J et al. in 1992<sup>[3]</sup>. For the first time since HarVey J D et al. used a red light pump of PCF to observe blue and near infrared range of wavelength conversion in 2003<sup>[4-5]</sup>, the development of wavelength conversion based on PCF has been developed rapidly. For example, Andersen etc. used PCF which had 50 meters to realize the wavelength conversion of 40Gb/s RZ signal<sup>[6]</sup>. Chow K K et al. used PCF which had 64 meters to realize the wavelength conversion of 10Gb/s NRZ signal in the range of 1535–1575 nm<sup>[7]</sup>. Wang Qiuguo et al. researched wavelength conversion based on FWM in the dispersion–flattened PCF<sup>[8]</sup>. Shao Xiaojie et al. researched wavelength conversion based on FWM in the high nonlinear dispersion–flattened PCF which had 25 meters<sup>[9]</sup>.

The purpose of this paper is to provide a theoretical investigation on all – optical wavelength conversion based on stimulated Raman scattering, and PCF is chosen as the transmission medium. This theoretical model is presented to Gong Jiamin et al.<sup>[10]</sup> By numerical simulation of theoretical model with Matlab and OptiSystem, the feasibility of the designed scheme is verified.

## 1 Theoretical model

Ignoring the influence of spontaneous emission and backward Rayleigh scattering, the mathematical theory model of designing all –optical wavelength

conversion is  $N -$  channel forward transient coupled equation which was based on the stimulated Raman scattering<sup>[11]</sup>.

$$\frac{\partial n_i(z,t)}{\partial z} + \frac{1}{\mu_i} \frac{\partial n_i(z,t)}{\partial t} = -\alpha n_i(z,t) + \sum_{j=1}^N (r_i - r_j) n_j(z,t) n_i(z,t) \quad i=1 \cdots N \quad (1)$$

$$n_i(z,t)|_{z=0} = n_i(t) \quad i=1 \cdots N \quad (2)$$

Where  $n_i(t)$  denote initial photon flux of each signal at  $z=0$  and  $t$  moment, which changes with  $t$ ;  $n_i(z,t)$  and  $n_j(z,t)$  denote the  $i$ -th and  $j$ -th channel photon flux at  $z$  and  $t$  moment;  $\alpha_i$  is the  $i$ -th channel linear attenuation coefficient of optical signal;  $\mu_i$  is the  $i$ -th channel group velocity of optical signal. In the case of no account of the group velocity mismatch caused by dispersion, assumed that the group velocity of each channel signal in the fiber is  $\mu$  and equal linear attenuation coefficient. The power form of the analytical solution of formula (1) satisfies the formula (2) is:

$$\left\{ \begin{aligned} p_i(z,t) &= p_i(t-z/u) \cdot e^{-\alpha z} \frac{p_{\Sigma}(t-z/u)}{\sum_{j=1}^N \frac{\bar{v}}{v_j} \cdot p_j(t-z/u) \cdot e^{G_j}} \\ i &= 1, 2 \cdots N \\ p_i(z,t) &= n_i(z,t) \cdot h\bar{v}_i \\ p_{\Sigma}(t-z/u) &= \sum_{j=1}^N p_j(t-z/u) \cdot \frac{\bar{v}}{v_j} \\ G_{ji} &= -\frac{k}{\lambda M A e} (\bar{v}_j - \bar{v}_i) \cdot p_{\Sigma}(t-z/u) \cdot L e \end{aligned} \right. \quad (3)$$

$p_i(t-z/u)$  is the  $i$ -th channel optical power for  $t$  moment at  $z$ ;  $\bar{v}_i$  is the  $i$ -th channel wavelength number ( $\bar{v}_i = \lambda_i^{-1}$ );  $G_{ji}$  is the gain of the  $i$ -th and  $j$ -th channel whose unit is  $\text{cm}^{-1}$ ;  $L e$  denotes the effective interaction length at  $z$ ;  $h\bar{v}$  is average photon energy.  $M$  is polarization coefficient ( $1 \leq M \leq 2$ );  $A e$  is effective cross-sectional area of fiber;  $\bar{\lambda}$  denotes the average value of the channel wavelength and it is a dimensionless quantity,  $k$  is the slope of the least square fitting line.

Fiber Raman wavelength conversion based on amplification principle of SRS in optical fiber. In general, the pumping signal optical power is far greater than the probing light power. In this case, if the first channel is the pumping signal light, and the probing light in order of priority, the formula (3) can be simplified:

$$p_i(z,t)=p_i(t-z/u) \cdot e^{-\alpha z} \cdot e^{G_p} \quad i=2 \cdots N \quad (4)$$

$$G_{ii}=-\frac{k}{\lambda_1 M A e}(\tilde{\nu}_1-\tilde{\nu}_i) \cdot p_1(t-z/u) \frac{\tilde{\nu}}{\nu_1} L e \quad (5)$$

$$L e=\frac{1-e^{-\alpha z}}{\alpha} \quad (6)$$

By analyzing formula (4) and (5):  $G_{ii}$  only changes with pumping signal optical power based on the given fiber length and continuous probing light, so getting the gain with the pumping optical power changes is  $G=\exp(-\alpha z-G_{ii})$ . Because of the gain changes with the change of the pumping light, the amplification factor of continuous probing light changes as the pumping signal light changes. It is equivalent to use the pumping light to modulate the probing light, and the energy and information of the pumping light will be transmitted to the continuous probing light. The all optical wavelength conversion is achieved.

## 2 Mathematical model simulation and analysis

Figure 1 shown that the Raman gain spectrum of PCF when the pump wavelength is 1450 nm<sup>[12]</sup>. It can be seen that the PCF has a larger Raman gain coefficient and wider frequency shift than traditional quartz fiber.

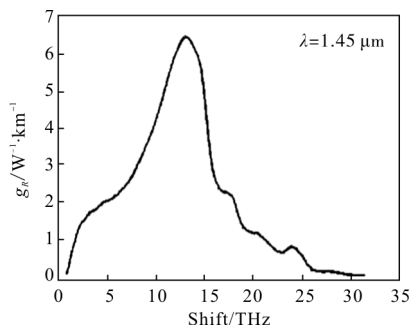

Fig.1 Raman gain spectrum of PCF

The SRS effect of PCF is stronger than the quartz fiber under the same conditions. Therefore, the PCF is more suitable as a wavelength conversion medium.

Selecting the frequency shift range of [300,400]cm<sup>-1</sup> ([9.0,12.0]THz) and fitting a straight line, so the frequency shift range Raman gain spectrum curve can be expressed as follows:

$$g(\Delta\tilde{\nu})=k(\Delta\tilde{\nu})+b \quad (300 \leq \Delta\tilde{\nu} \leq 400) \text{cm}^{-1} \quad (7)$$

Where  $k$ ,  $b$  are the slope and intercept of least squares fitting line, the value is:  $k=2.70 \times 10^{-6}/\text{W}^{-1}$ ;  $b=4.65/\text{W}^{-1} \cdot \text{km}^{-1}$ . So its gain can be written as:

$$G_{ii}=-\frac{k(\tilde{\nu}_1-\tilde{\nu}_i)+b}{\lambda_1} \cdot p_1(t-z/u) \frac{\tilde{\nu}}{\nu_1} L e \quad (8)$$

Simulated the theoretical model based on Matlab. Parameters are used in the simulation process as follows: the wavelength is 1450 nm, the converted wavelength is 1550 nm, the peak power of the pumping light is 0.5 W, the length of the PCF is 500 m, the linear attenuation coefficient is 9 dB/km, the effective cross-sectional area of the fiber is  $9.5 \times 10^{-12} \text{m}^2$ , the polarization coefficient is "2". The generated attenuation of the pumping light and probing light is negligible which to be converted by coupler. The waveform was obtained as shown in Fig.2 according to formulas (4), (5) and (6).

From the comparison of the waveforms in Fig.2, we

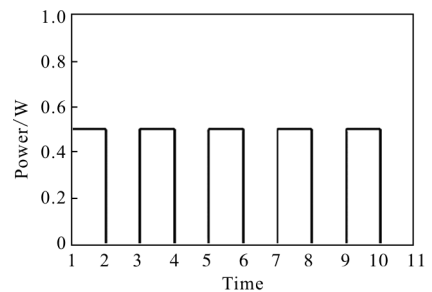

(a) Pumping light waveform before conversion

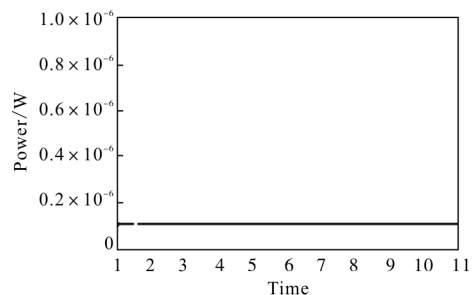

(b) Continuous probing light waveform

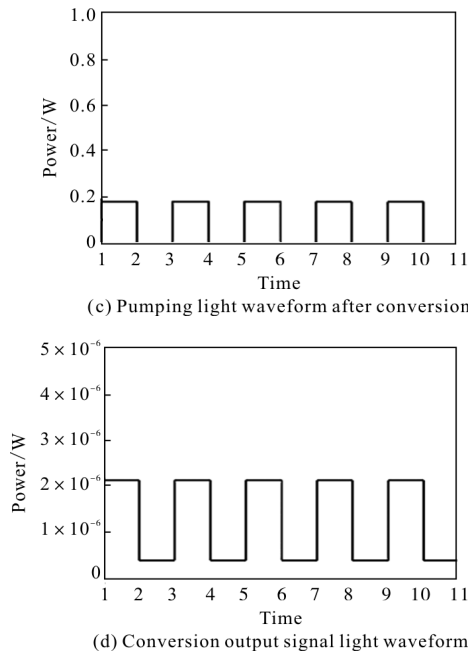

Fig.2 Conversion process waveform

can see: (1) The pumping signal optical power become smaller; (2) The waveform of the converted output signal and the pumping signal are identical. It means the wavelength conversion is achieved by using the SRS effect of PCF.

The peak value and zero value of pumping signal is "1" code and "0" code respectively. So the continuous probing light is amplified by the pumping signal light only in the "1" code and has small amplification in the

"0" code. The converted output signal wave form was shown as Fig.2 (d) showed.

### 3 Simulation results and analysis by OptiSystem

#### 3.1 Principle of simulation

Under the guidance of these theories, and based on stimulated Raman scattering of all-optical wavelength conversion was designed and simulated. Figure 3 shown a schematic diagram of PCF all-optical wavelength conversion. Due to the signal lights which transmit in the optical channels are generally weak (usually only a few microwatts, or even less) and through the transmission there will be a certain loss of distance, first, it must be amplification and shape to the pumping signal light  $\lambda_1$ . Then the pumping signal light  $\lambda_1$  and the probing lights ( $\lambda_2, \lambda_3 \dots \lambda_N$ ) are coupled into a PCF by using a  $N \times 1$  optical coupler. The probing light is a continuous light, and it does not carry any information. Since multiple probing lights stimulated Raman effect in optical fiber, the energy and information of the signal light  $\lambda_1$  will be transmitted to the probing lights, and then the original signal light  $\lambda_1$  was filtered by wave filter. This process is achieved all-optical wavelength conversion.

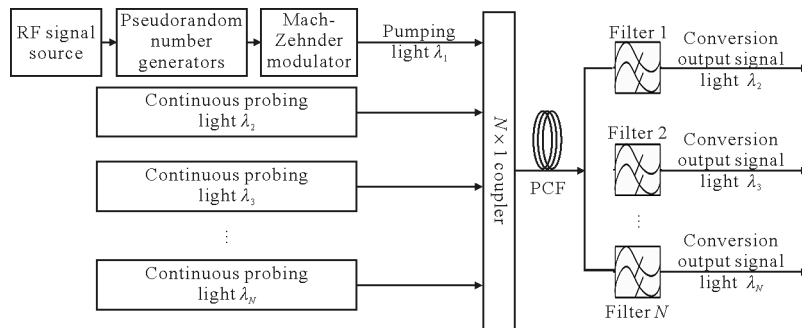

Fig.3 Schematic diagram of all optical wavelength conversion in PCF

#### 3.2 Simulation analysis

In the simulation of OptiSystem, using a continuous laser as the source of light, and the spectral width is 1 MHz. The parameters are set as follows: the signal wavelength is 1 450 nm and its power is 2 W, selecting

four probing lights whose wavelengths are 1 515 nm, 1 529 nm, 1 545.8 nm, 1 562.5 nm and their power are -30 dBm. Ignoring the coupler on attenuation of the pumping and probing power. The high nonlinearity PCF parameters are as follows: the PCF length is

500 m, the attenuation coefficient is 9 dB/km, effective cross-sectional area is  $9.5 \mu\text{m}^2$ , dispersion coefficient  $0.05 \text{ ps/nm} \cdot \text{km}$ , dispersion slope is  $0.00 \text{ lps}/(\text{nm}^2 \cdot \text{km})$ , the responsivity of the photodetector is set to  $1 \text{ A/W}$ , dark current is  $10 \text{ Na}$ . At the same time, ignoring spontaneous emission noise and shot noise. By analyzing of the spectrum, signal waveform and eye diagram, we will illustrate the simulation results.

### 3.2.1 Spectrum

Figure 4 is the spectral diagram of the signal light and the probing lights. The change of the signal optical power and the spectrum can be visually observed. The following conclusions can be drawn by comparing the changes of the two pictures:

(1) The optical power of the probing light is increased, and the pumping signal optical power becomes small.

The optical power of each probing light is significantly increased, which is due to the effect of SRS between the probing light and the pumping signal. Part of the energy was transmitted from the pumping light to the probing light, so that each probing light is amplified.

(2) The spectrums of the probing lights are broaden, and become messy.

As shown in Fig.4 (a), at the beginning of the probing light, it was very weak, the spectrums were amplified and interaction after the effect of SRS. It produces a spectrum of effects that shown in (b). So the SRS amplification effect in optical fiber was described.

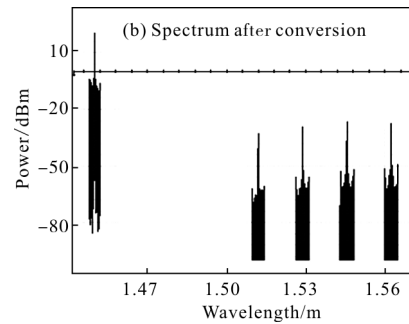
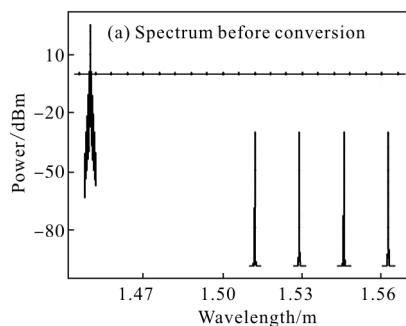
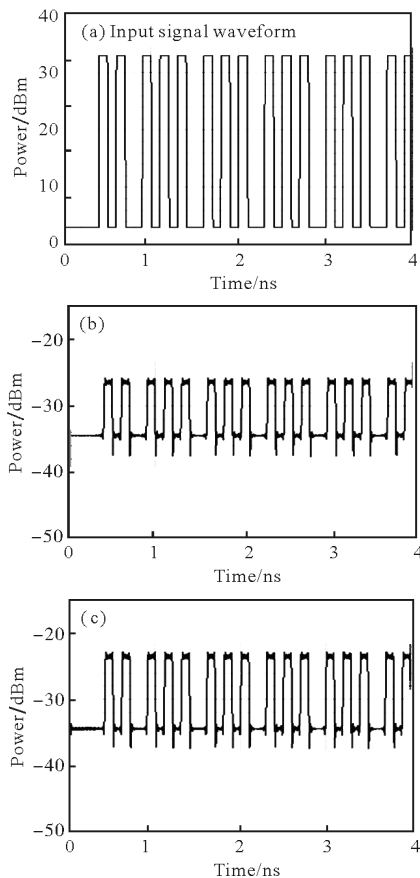

Fig.4 Spectrum of the signal light and the probing lights

### 3.2.2 Signal waveform

In the simulation, the input signal is NRZ, and the bit sequence was set to "0 101 001". The signal waveform is shown in Fig.5 (a). The converted output signal light waveforms of wavelength 1515nm, 1529nm, 1545.8nm, 1562.5nm are shown in Fig.5 (b), (c), (d) and (e). As it can be seen from the figure, the 4 ways converted wavelengths are exactly as same as the pumping wavelength. It proves that this process can realize all-optical wavelength conversion.



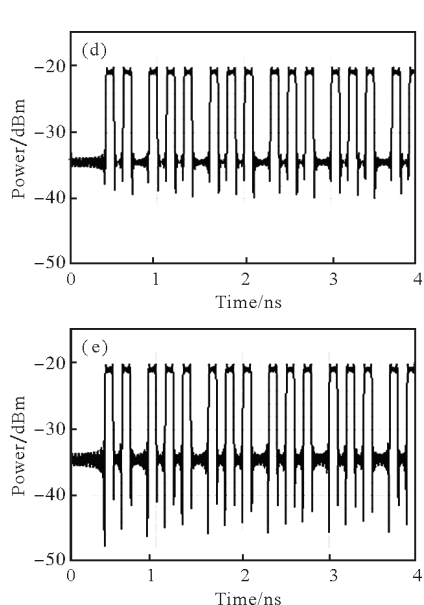

Fig.5 Signal light and four way probing lights waveform

### 3.2.3 Eye diagram

Figure 6 is the eye diagram of the 4 ways converted probing light. As shown in figure the

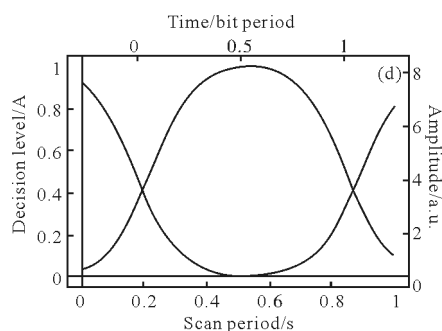
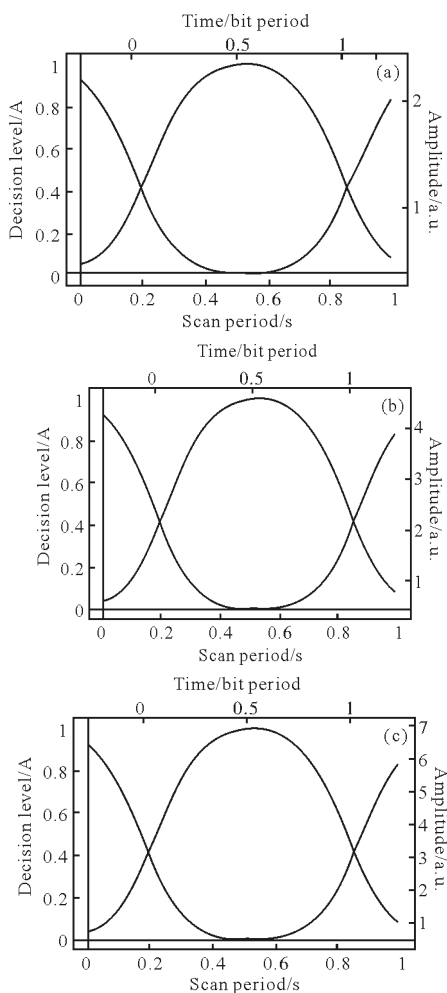

Fig.6 Eye diagram of 4 ways converted probing lights

simulated eye diagram has a clear line and it has a good opening degree. It is illustrated each converted probing light that has high signal–noise ratio and small inter–symbol interference, which in line with the requirements of the communication system.

## 4 Conclusions

Based on the SRS in optical fiber, using the Raman gain spectrum curve of PCF fitting a straight line. Then the numerical simulation and analysis of the converted signal is carried out by using the transient equation of the forward coupled wave. Based on the theoretical model, the schematic diagram of all optical wavelength conversion based on SRS in PCF is designed, and using OptiSystem to simulate it. By analyzing the spectrum, signal waveform and eye diagram of the converted probing lights, the feasibility of the method is demonstrated.

## References:

- [1] Yoo S J B. Wavelength conversion technologies for WDM network applications [J]. *Journal of Lightwave Technology*, 1996, 14(6): 955–966.
- [2] Blumenthal D J. Routing packets with light [J]. *Scientific American*, 2001, 285(1): 1144–1148.
- [3] Russell P. Photonic crystal fibers [J]. *Journal of Lightwave Technology*, 2007, 24(12): 4729–4749.
- [4] Harvey J D, Rainer L, Stephane C, et al. Scalar modulation instability in the normal dispersion regime by use of a photonic crystal fiber.[J]. *Optics Letters*, 2003, 28(22):2225–2227.
- [5] Harvey J D, Leonhardt R, Wong K L G, et al. Optical parametric amplification in the normal dispersion regime using a PCF[J]. *IEEE*, 2004, 2:99–102.

- [6] Andersen P A, Tokle T, Yan G, et al. Wavelength conversion of a 40-Gb/s RZ-DPSK signal using four-wave mixing in a dispersion-flattened highly nonlinear photonic crystal fiber [J]. *Photonics Technology Letters IEEE*, 2005, 17 (9): 1908-1910.
- [7] Chow K K, Shu C, Lin C, et al. Polarization-insensitive widely tunable wavelength converter based on four-wave mixing in a dispersion-flattened nonlinear photonic Crystal fiber [J]. *Photonics Technology Letters IEEE*, 2005, 17(3): 624-626.
- [8] Wang Qiuguo, Yang Bojun, Zhang Lan, et al. Experiment study of wavelength conversion in a dispersion-flattened photonic crystal fiber[J]. *Chinese Optics Letters*, 2007, 5(9): 538-539.
- [9] Shao X J, Yang D X, Geng D. Wavelength conversion based on four-wave mixing in photonic crystal fiber [J]. *Acta Photonica Sinica*, 2009, 38(3): 652-655.
- [10] Xu Junhua, Leng Bin, Zhao Yun, et al. All-optical multi-wavelength conversion coupler based on stimulated Raman scattering in optical Fiber [J]. *Acta Photonica Sinica*, 2013, 42(9): 1009-1017.
- [11] Gong Jiamin. Dense wavelength division multiplexing in a quartz optical fiber communication systems stimulated Raman scattering and stimulated Brillouin scattering effect [D]. Xi'an: Xi'an Jiaotong University, 1999.
- [12] Tajima K, Zhou J, Nakajima K, et al. Ultra low loss and long length photonic crystal fiber [C]//Optical Fiber Communication Conference, 2004: 7-10.